

Jacob White Flat Belt Conveyors

## STANDARD FLAT BELT CONVEYOR

Jacob Whites conveyors are constructed from stainless steel, and are IP54 rated.

A food grade belt is supplied as standard but can be changed to suite customer requirements.

All conveyors come with standard belt widths of (100,200,300,400 & 500mm wide).

Customers can specify lengths from 500mm to 4m & heights can be specified to suite all needs

The main drive to the conveyor is from a A/C variable speed motor that is controlled by an inverter.

The transmission from the motor to the conveyors drum roller is supplied by a heavy-duty chain & sprocket drive.

The standard speed range is from 10 – 80 m/min depending on the customer's requirements.

The leading, trailing and idler rollers are designed to be easily removable to reduce maintenance time.

### Technical Data

Speed :-  
Variable up to 80 metres/min

Electrical:-  
0.37kW AC motor, 230V 50~60 Hz giving variable speed

Sizes : -  
Length = 500mm to 4000mm  
Width = 100mm to 500mm  
Height = 200mm to 1500mm

**Jacob White (Packaging) Ltd**  
Riverside Industrial Estate  
Dartford, Kent DA1 5BY  
United Kingdom

Tel: 01322 272 531  
Fax: 01322 270 692

E-mail: [info@jacobwhite.com](mailto:info@jacobwhite.com)  
Web site: [www.jacobwhite.com](http://www.jacobwhite.com)

**Jacob White Automation & System Resources**  
Suite 306, Amberland Plaza,  
J Vargas Ave, Ortigas Centre, Pasig,  
Metro Manila  
Philippines

Tel: (632) 634 5482  
Fax: (632) 634 0318

**Jacob White Asia**  
c/o **Hanco Engineering & Manufacturing**  
Ji Raya Kelapa Sawit  
Ruko Gading Serpong  
Blok BD No. 31  
Tangerang 15810  
Indonesia

**AVV Industrial**  
Packaging machines  
& Product handling  
Pauvreweg 29  
4879 NJ Etten-Leur  
The Netherlands  
Tel: +31 765040695  
Fax: +31 765040696

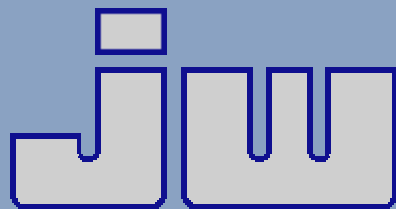
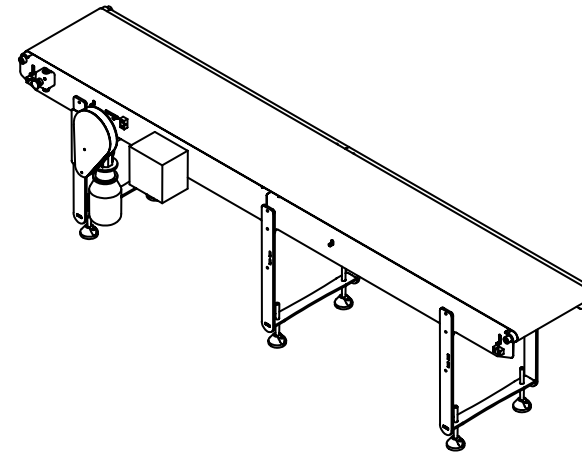
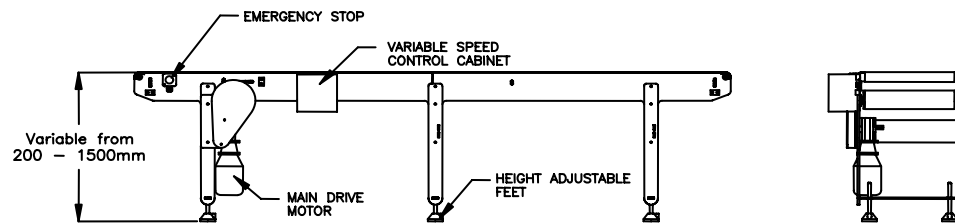
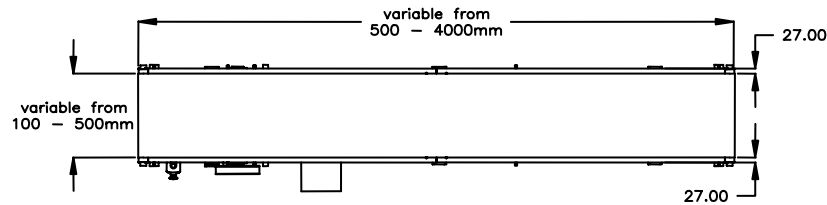

# Jacob White Packaging Flat Belt Conveyors

